

OIL QUANTITY (LITRES)	HL/300	HL/420
MINIMUM LEVEL	4	5
USEFUL OIL	38	55
TOTAL OIL	42	60

OILFREE POWER UNIT WEIGHT	HL/300	HL/420
	50	60

MONO-PHASE MOTOR AIR 230V - 50Hz				
CV	KW	Ø	I <sub>N</sub> A	I <sub>A</sub> A
1	0.75	19	6	⚠
1.5	1.1	19	7.6	
2	1.5	19	8.95	
2.5	1.8	19	12.8	
3	2.2	19	14.7	

TREE-PHASE MOTOR AIR 400-415V - 50Hz (230-240V - 50Hz)				
CV	KW	Ø	I <sub>N</sub> A	I <sub>A</sub> A
1	0.75	19	1.9 (3.3)	⚠
1.5	1.1	19	3 (5.2)	
2	1.5	19	3.6 (6.2)	
3	2.2	19	6.6 (11.4)	

- ⚠ - REF DIMENSION CAP FOR TWO-SOLENEID VALVE (ON CAN BE SUPPLIED OPTIONALLY)
- ⚠ - STARTING CURRENT:  $I_A = I_N \times 3$

MOD.	COVER
HL300	YES
HL420	YES
HL300AR	NO
HL420AR	NO

SPEED OF RAM IN UPWARD DIRECTION M/SEC (AVERAGE LOAD)	PUMP L/1' (Ø 19)				RAM	STATIC PRESSURE IN BARS																			TOTAL LOAD (USEFUL LOAD+CAR+CAR-FRAME+ACC. =kg)														
	23	18	12	8		Ød	e	16	17	18	19	20	21	22	23	24	25	26	27	28	29	30	31	32		33	34	35	36	37	38	39	40	41	42	43	44	45	46
	0.19	0.15	0.10	0.06		50	5	281	320	359	398	438	477	516	556	595	634	673	713	752	791	830	870	7.5		267	306	345	384	424	463	502	542	581	620	659	699	738	777
0.13	0.10	0.07	0.04	60	5	392	450	505	562	618	675	732	788	845	901	958	1015	1071	1128	1184	1240	7.5	368	425	481	538	594	651	707	764	820	877	933	990	1046	1103	1160	1216	
					5	535	612	688	766	843	920	997	1074	1151	1227	1305	1382	1458	1535	1612	1689	7.5	502	579	656	733	810	887	964	1041	1118	1195	1272	1349	1426	1503	1580	1657	
0.09	0.07	0.05	0.03	70	5	704	805	905	1006	1106	1207	1307	1408	1508	1609	1709	1810	1910	2011	2111	2212	7.5	704	805	905	1006	1106	1207	1307	1408	1508	1609	1709	1810	1910	2011	2111	2212	
					5	649	749	850	950	1051	1151	1252	1352	1453	1554	1654	1755	1855	1956	2056	2157	12	566	667	767	869	968	1069	1169	1270	1370	1471	1571	1672	1772	1873	1973	2074	
0.06	0.05	0.03	0.02	85	5	890	1017	1144	1271	1398	1526	1653	1780	1908	2035	2162	2289	2416	2544	2671	2798	7.5	722	836	949	1063	1176	1290	1403	1517	1630	1744	1857	1971	2084	2198	2311	2425	
					5	890	1017	1144	1271	1398	1526	1653	1780	1908	2035	2162	2289	2416	2544	2671	2798	7.5	816	944	1071	1198	1325	1453	1580	1707	1834	1962	2089	2216	2343	2471	2598	2725	
0.06	0.05	0.03	0.02	90	5	890	1017	1144	1271	1398	1526	1653	1780	1908	2035	2162	2289	2416	2544	2671	2798	7.5	717	844	971	1098	1225	1353	1480	1607	1734	1861	1988	2116	2243	2370	2497	2624	
					5	890	1017	1144	1271	1398	1526	1653	1780	1908	2035	2162	2289	2416	2544	2671	2798	7.5	816	944	1071	1198	1325	1453	1580	1707	1834	1962	2089	2216	2343	2471	2598	2725	

RAM Ø	8	12	18	23	MONO-PHASE 50Hz 230V ± 5%	MOTOR POWER AIR H.P. (KW)
50	1 (0.75) Ø19	1.5 (1.1) Ø19	2 (1.5) Ø19	3 (2.2) Ø19	1.5 (1.1) Ø19	1.5
60	1 (0.75) Ø19	1.5 (1.1) Ø19	2 (1.5) Ø19	3 (2.2) Ø19	2 (1.5) Ø19	2
70	1.5 (1.1) Ø19	2 (1.5) Ø19	3 (2.2) Ø19	4 (3.0) Ø19	2.5 (1.8) Ø19	2.5
80	1 (0.75) Ø19	1.5 (1.1) Ø19	2 (1.5) Ø19	3 (2.2) Ø19	1.5 (1.1) Ø19	1.5
85	1 (0.75) Ø19	1.5 (1.1) Ø19	2 (1.5) Ø19	3 (2.2) Ø19	2 (1.5) Ø19	2
90	1.5 (1.1) Ø19	2 (1.5) Ø19	3 (2.2) Ø19	4 (3.0) Ø19	2.5 (1.8) Ø19	2.5

- THE WEIGHT INDICATED IN THIS TABLE HAS BEEN CALCULATED CONSIDERING THE ROD WEIGHT FOR A MAXIMUM STROKE ( SEE DWG. 9020/... 9030/... )

	<b>TABLE TO DETERMINE THE VALUES OF PRESSURE - SPEED - PUMP FLOW - MOTOR IN AIR (50Hz) FOR HL POWER UNIT, RELATED TO ROD Ø AND LOAD</b>	DATE 10/18
		DWG. N. 9018/HL-50Hz

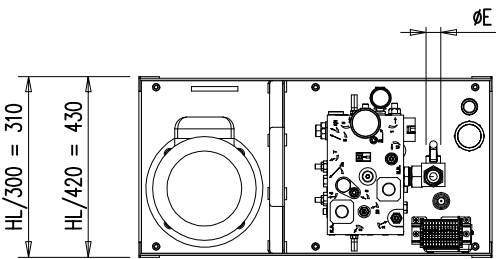
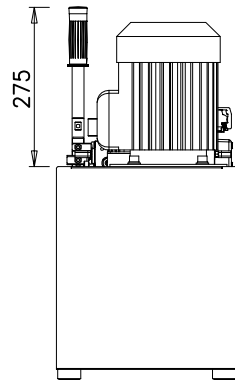
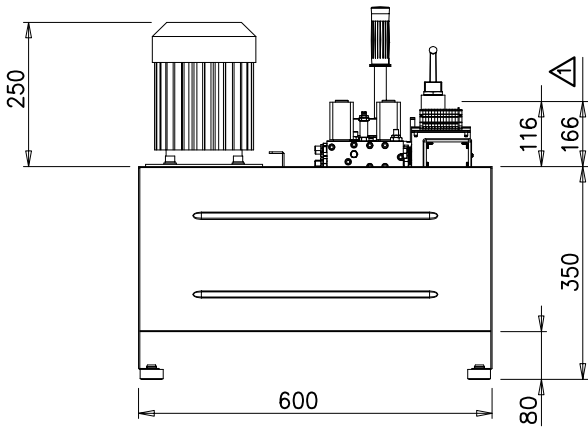

MOD.	COVER
HL300	YES
HL420	YES
HL300AR	NO
HL420AR	NO

OIL QUANTITY (LITRES)	HL/420-MH2V		
	HL/300-MH2V	8/23 Litres 30 Litres	
MINIMUM LEVEL	4	5	8
USEFUL OIL	38	55	52
TOTAL OIL	42	60	60

POWER UNIT WEIGHT WITHOUT OIL	HL/300-MH2V	HL/420-MH2V
	Kg. 45	Kg. 55

MONO-PHASE MOTOR AIR 230V - 50Hz				
CV	KW	Ø	I <sub>N</sub> A	I <sub>A</sub> A
1	0.75	19	6	⚠
1.5	1.1	19	7.6	
2	1.5	19	8.95	
2.5	1.8	19	12.8	
3	2.2	19	14.7	
4	3	19	19.8	

THREE-PHASE MOTOR AIR 400-415V - 50Hz (230-240V - 50Hz)				
CV	KW	Ø	I <sub>N</sub> A	I <sub>A</sub> A
1	0.75	19	1.9 (3.3)	⚠
1.5	1.1	19	3 (5.2)	
2	1.5	19	3.6 (6.2)	
3	2.2	19	6.6 (11.4)	
4	3	19	7.4 (12.8)	

⚠ - ONLY WITH BI-SOLENOID ELECTROVALVES (ON DEMAND))

⚠ - STARTING CURRENT: ~ I<sub>A</sub> = I<sub>N</sub> x 3

SPEED OF RAM IN UPWARD DIRECTION M/SEC (M.LOAD)	PUMP L/1'					RAM	STATIC PRESSURE IN BAR																				TOTAL LOAD (P+Q=KG)												
	PUMP L/1'		PUMP L/1'				Ød	e	STATIC PRESSURE IN BAR																														
	(Ø 19)	(Ø 19)	30	23	18				12	8	12	14	15	16	17	18	19	20	21	22	23	24	25	26	27	28		29	30	31	32	33	34	35	36	37	38	39	40
0.25	0.19	0.15	0.10	0.06	50	5	202	241	281	320	359	398	438	477	516	556	595	634	673	713	752	791	830	870															
						7.5	188	227	267	306	345	384	424	463	502	542	581	620	659	699	738	777	816	856															
0.17	0.13	0.10	0.07	0.04	60	5	280	335	392	450	505	562	618	675	732	788	845	901	958	1015	1071	1128	1184	1240															
						7.5	255	312	368	425	481	538	594	651	707	764	820	877	933	990	1046	1103	1160	1216															
0.12	0.09	0.07	0.05	0.03	70	5	380	458	535	612	688	766	843	920	997	1074	1151	1227	1305	1382	1458	1535	1612	1689															
						7.5	348	425	502	579	656	733	810	887	964	1041	1118	1195	1272	1349	1426	1503	1580	1657															
0.10	0.07	0.06	0.04	0.02	80	5	500	604	704	805	905	1006	1106	1207	1307	1408	1508	1609	1709	1810	1910	2011	2111	2212															
						7.5	448	548	649	749	850	950	1051	1151	1252	1352	1453	1554	1654	1755	1855	1956	2056	2157															
0.08	0.06	0.05	0.03	0.02	85	7.5	495	609	722	836	949	1063	1176	1290	1403	1517	1630	1744	1857	1971	2084	2198	2311	2425															
						5	630	762	890	1017	1144	1271	1398	1526	1653	1780	1908	2035	2162	2289	2416	2544	2671	2798															
0.08	0.06	0.05	0.03	0.02	90	7.5	562	689	816	944	1071	1198	1325	1453	1580	1707	1834	1962	2089	2216	2343	2471	2598	2725															
						12	462	590	717	844	971	1098	1225	1353	1480	1607	1734	1861	1988	2116	2243	2370	2497	2624															

SPEED OF RAM IN UPWARD DIRECTION M/SEC (M.LOAD)	Ød	MONO-PHASE MOTOR AIR HP (KW)				THREE-PHASE MOTOR AIR HP (KW)			
		1 (0.75) Ø19	1.5 (1.1) Ø19	2 (1.5) Ø19	2.5 (1.8) Ø19	1 (0.75) Ø19	1.5 (1.1) Ø19	2 (1.5) Ø19	2.5 (1.8) Ø19
8	8	1 (0.75) Ø19				1.5 (1.1) Ø19			
12	12	1 (0.75) Ø19		1.5 (1.1) Ø19		2 (1.5) Ø19		2.5 (1.8) Ø19	
18	18	1.5 (1.1) Ø19			2 (1.5) Ø19		2.5 (1.8) Ø19		
23	23	2 (1.5) Ø19		2.5 (1.8) Ø19		3 (2.2) Ø19		4 (3) Ø19	
30	30	2.5 (1.8) Ø19			3 (2.2) Ø19		4 (3) Ø19		
8	8	1 (0.75) Ø19				1.5 (1.1) Ø19			
12	12	1 (0.75) Ø19		1.5 (1.1) Ø19		2 (1.5) Ø19		2.5 (1.8) Ø19	
18	18	1 (0.75) Ø19			1.5 (1.1) Ø19		2 (1.5) Ø19		
23	23	1.5 (1.1) Ø19		2 (1.5) Ø19		3 (2.2) Ø19		4 (3) Ø19	
30	30	2 (1.5) Ø19			3 (2.2) Ø19		4 (3) Ø19		

- THE WEIGHT INDICATED IN THIS TABLE HAS BEEN CALCULATED CONSIDERING THE ROD WEIGHT FOR MAXIMUM STROKE (SEE DWG. 9020/... 9030/...)

UT	TABLE TO CALCULATE THE VALUES OF PRESSURE-SPEED-PUMP FLOW-MOTOR IN AIR (50Hz) FOR HL-MH2V POWER UNIT, RELATED TO ROD Ø AND LOAD	DATE 10/18
		DWG. N° 9018/HL-MH2V/50Hz