

DIMENSIONI E DATI TECNICI

PISTONE TIPO	STELO					CILINDRO					FONDELLO CILINDRO				VOLUME OLIO [l]		PESO TOTALE
	d	e	A	P _{rx}	P _{cx}	D	e _{cyl}	bc	d2	d3	e1	u1	h1	s1	V _c	V _r	kg
80x5	80	5	5027	0,0092	---	100	5	89	110	110					5,0	1,3	20 x S + 22
80x7,5		7,5		0,013	5,6												25 x S + 23
80x12		12		0,020													30 x S + 24
90x5	90	5	6362	0,011	---	110	5	95.5	125	120	24	6	24	6,5	6,4	1,5	23 x S + 24
90x7,5		7,5		0,015	7,2												28 x S + 26
90x12		12		0,023													40 x S + 37
100x5	100	5	7854	0,012	---	120	5	102	131	130					7,9	1,6	26 x S + 28
100x7,5		7,5		0,017	5,2												31 x S + 29
100x12		12		0,026													38 x S + 30

Corsa minima = 1750 mm

Corsa massima (non giuntato) = 9000 mm

Corsa massima (giuntato) = 12000 mm

Pressione statica massima = 5 MPa

UT			DATA	04/23
		PISTONE HL COMPACT	DIS. N°	9180/10 (1/2)

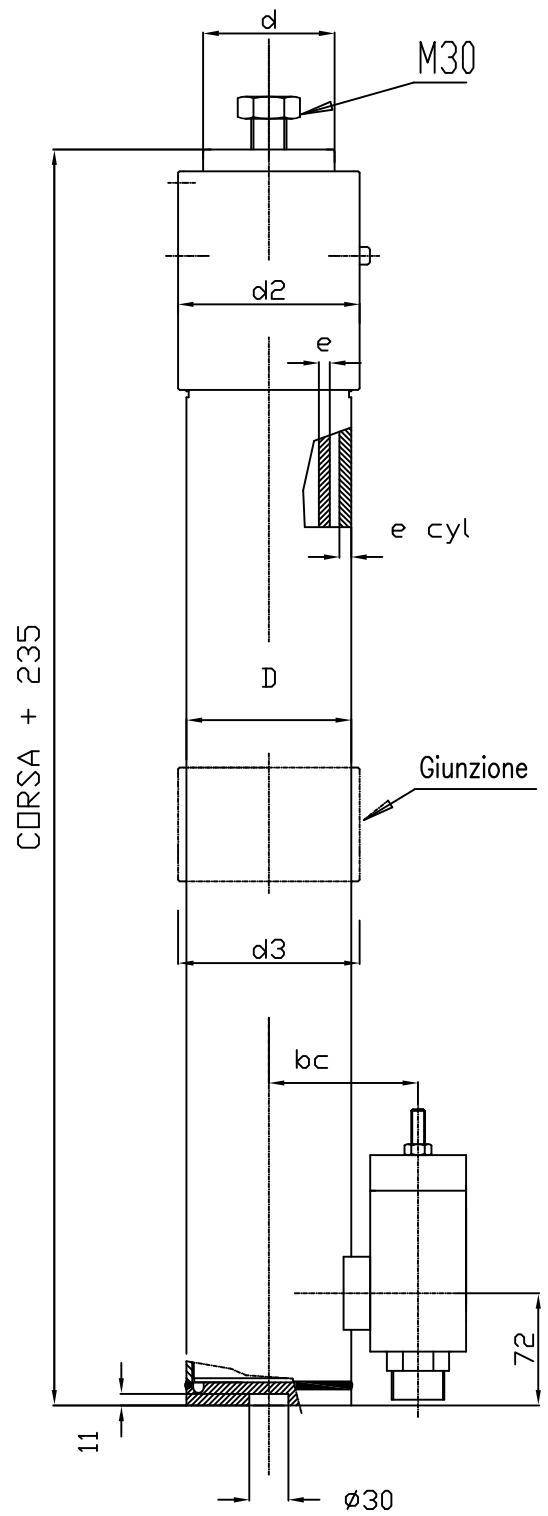
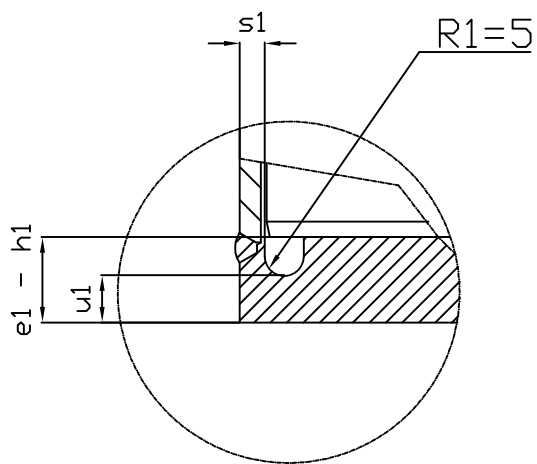

UT	

PISTONE HL COMPACT

DATA 04/23

DIS. N° 9180/10 (2/2)